



System 20

HORIZONTAL TURNTABLE SYSTEM

The Lincoln Electric® System 20 is a pre-engineered turntable robotic welding system that features the latest equipment and welding process technologies from Lincoln Electric.

- **Power Wave® i400 Power Source**
High-speed, multi-process robotic welding source.
- **AutoDrive™ 4R90 Wire Feeder**
4-roll gear-driven system.
- **FANUC ARC Mate® 100iC**
Universal process robotic arm featuring the industry's fastest air-cut movements.

The system's servo-driven positioners are nearly maintenance-free with no mechanical components to fail, such as cylinders, brakes, controls, etc. It's ideal for small-to-medium sized parts that do not require reorientation.



Modular workholding
2-sided system with optional expansion to a 3- or 4-sided system.



Robust palletized steel structure includes forklift pockets for easy placement.

Ultra-small footprint optimizes floor space.



Roll-away doors allow easy robot programming and ease of accessibility for preventative maintenance.



Clearly marked push-button controls ensure simple operation.



Lincoln Electric System 20 with Power Wave® i400 Power Source, AutoDrive® 4R90 Wire Feeder and FANUC ARC Mate® 100iC



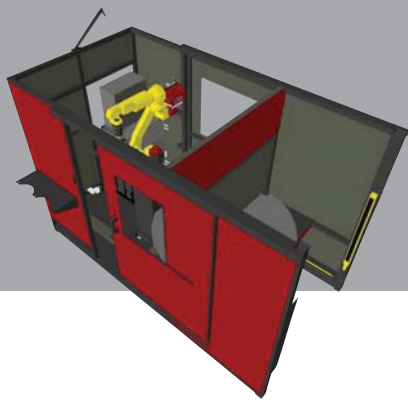

System 20

HORIZONTAL TURNTABLE SYSTEM

Standard Specifications

Robot Arm	FANUC ARC Mate® 100iC, Teach Pendant and FANUC ArcTool™ welding software
Power Source and Feeder	Power Wave® i400 and AutoDrive® 4R90
Table and Dimensions	Fast index, FANUC Servo driven turntable – 58" dual-zone turntable system
Weight Capacity	600 lbs (272 kg) per side maximum
Index Time	2.2 seconds
Weld Cell Controls	Intuitive push-button operator controls
Safety	Fully integrated safety rated devices, RIA 15.06-99 compliant
Training	3-day expert robotic instruction from AWS certified robotic arc welding instructors.
Documentation	Complete system kit: operator manuals, maintenance guides, spare parts guides, calibration numbers, serial numbers, prints, supplier references and specifications, electronic manuals and tools.

Featured Options

- Power REAM® – Robotic torch maintenance center, wire cutting, reaming and anti-spatter spray station.
- Fume extraction: fume hood, or deluxe package with fume hood, light kit, fan and filter system.
- Ball-lock workholding solutions.
- On-site weld part programming.
- FANUC Robotics software options: Torch Guard, Password Protection, Through Arc Seam Tracking, Touch Sensing and WeldPRO™

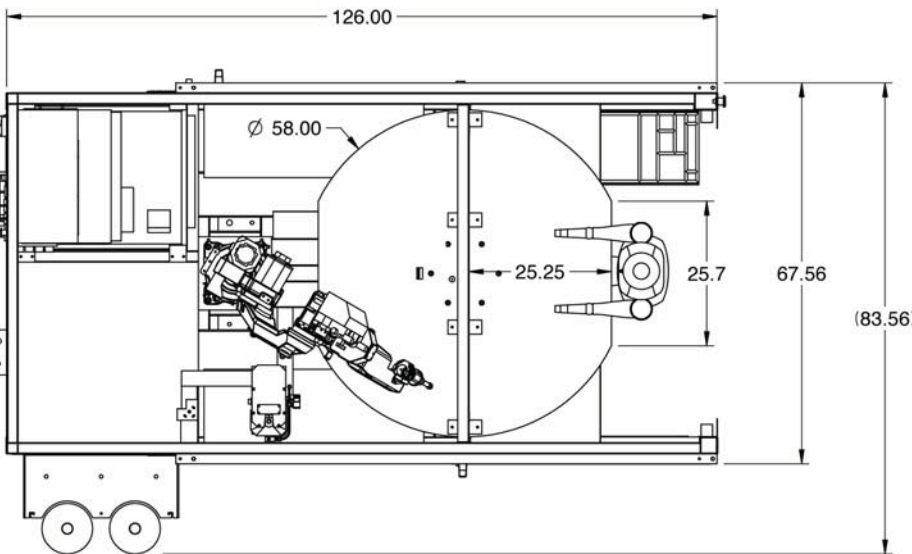
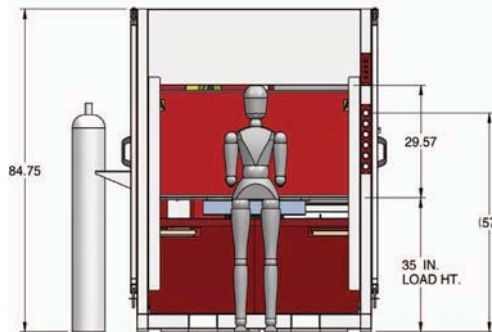

CUSTOMER ASSISTANCE POLICY

The business of The Lincoln Electric Company® is manufacturing and selling high quality welding equipment, consumables, and cutting equipment. Our challenge is to meet the needs of our customers and to exceed their expectations. On occasion, purchasers may ask Lincoln Electric for information or advice about their use of our products. Our employees respond to inquiries to the best of their ability based on information provided to them by the customers and the knowledge they may have concerning the application. Our employees, however, are not in a position to verify the information provided or to evaluate the engineering requirements for the particular weldment. Accordingly, Lincoln Electric does not warrant or guarantee or assume any liability with respect to such information or advice. Moreover, the provision of such information or advice does not create, expand, or alter any warranty on our products. Any express or implied warranty that might arise from the information or advice, including any implied warranty of merchantability or any warranty of fitness for any customers' particular purpose is specifically disclaimed.

Lincoln Electric is a responsive manufacturer, but the selection and use of specific products sold by Lincoln Electric is solely within the control of, and remains the sole responsibility of the customer. Many variables beyond the control of Lincoln Electric affect the results obtained in applying these types of fabrication methods and service requirements.

Subject to Change – This information is accurate to the best of our knowledge at the time of printing. Please refer to www.lincolnelectric.com for any updated information.

WORLD-CLASS WELDING AND AUTOMATION EXPERTISE

Lincoln Electric's strategic alliance with FANUC Robotics translates into an unparalleled combination of welding and robotics expertise, plus single-source efficiency. Whether you're considering your first automated cell, or you're ready to upgrade or enhance your existing robotic systems, there's no better partner than Lincoln Electric and FANUC Robotics.

EXCEPTIONAL CUSTOMER SERVICE

Lincoln Electric and FANUC Robotics have a global network of facilities and people to provide quick response and personalized attention. No matter where your welding operations are located today, no matter where they will be tomorrow, Lincoln Electric welding experts can provide local support, ready to create and implement solutions that fit your needs.

VALUABLE CUSTOM SOLUTIONS

While Lincoln Electric offers a wide spectrum of pre-engineered systems, we also offer the ability to modify or completely customize the creation of your weld cell to meet your precise needs. Contact us today!

Automation Service Hotline

1-888-935-3878

Automation After-Hours Technical Support

1-888-532-8001



LINCOLN
ELECTRIC

AUTOMATION
DIVISION

The Lincoln Electric Company

Automation Division

22221 Saint Clair Avenue

Cleveland, Ohio 44117-2522 USA

1-216-383-2667

Email: Automation@lincolnelectric.com

www.lincolnelectric.com/automated-solutions