

Power Wave S350

Processes

Stick, DC TIG, Pulsed DC TIG, MIG, Pulsed MIG, Flux-Cored

Product Number

K2823-3 Power Wave® S350
K3005-3 Power Wave S350 Ready-Pak® (Steel)

Input Voltage

208/230/380-415/460/575/1/3/50/60

Input Current @ Rated Output

3 Ph / 40% Duty Cycle: 39/35/19/17/14A
1 Ph / 40% Duty Cycle: 60/61/NA/NA/NA A

Output Range

5-350 Amps

Rated Output

GMAW: 350A/31.5V/40%
GMAW: 300A/29V/100%

Weight/Dimensions (H x W x D)

85 lbs. (38.6 kg)
20.40 x 14 x 24.80 in.
(518 x 356 x 630 mm)

See back for complete specs

Portable, Powerful, Multi-Process.

The multi-process Power Wave® S350 is packed with Lincoln Electric performance technology on both the input and output side. It provides an extremely fast arc response, includes over 65 standard welding waveforms for optimized performance on almost any application and efficiently converts input power to reduce operational costs – all in a compact, rugged case.

FEATURES

- ▶ **PowerConnect® Technology (Patent-Pending)** – Automatically adjusts to input power from 200-600V, 50 or 60 Hz, single phase or three phase. Welding output remains constant through the entire input voltage range.
- ▶ **Tribrid® Power Module** – Exceptional welding performance with high power factor and efficiency.
- ▶ **CheckPoint®** – A cloud-based system to view or analyze your welding data. Track equipment usage, store weld data, configure fault limits and more.
- ▶ **Optional 115V (10A) AC Duplex Auxiliary Power Receptacle** – Features patent-pending Surge Blocker™ Technology to ensure simultaneous welding performance is not compromised by high starting current devices such as grinders (typically requiring 60A or more peak surge current).
- ▶ **Compact and Durable Case** – IP23 rated to withstand harsh environments.
- ▶ **Standard Ethernet** – Allows for effortless software upgrades through powerwavesoftware.com

APPLICATIONS

- ▶ Construction
- ▶ Aerospace
- ▶ Fabrication
- ▶ Automotive
- ▶ Production
- ▶ Weld Training



Shown: K2823-1
Power Wave S350

WHAT'S INCLUDED

K2823-3 Base Unit Includes:

- ▶ 10 ft. (3.0 m) input power cord

RECOMMENDED WIRE FEEDERS

- ▶ Power Feed 84 Bench and Boom models
- ▶ Power Feed 25M

WAVEFORM CONTROL TECHNOLOGY® PROCESS CAPABILITIES

- ▶ Pulse
- ▶ Pulse-on-Pulse®
- ▶ Power Mode®
- ▶ RapidArc®
- ▶ Rapid X™ (with STT® Module)
- ▶ Upgradeable for additional processes to be developed in the future.

INPUT



OUTPUT



Two Year Extended Warranty available in the U.S.A. and Canada.



KEY CONTROLS

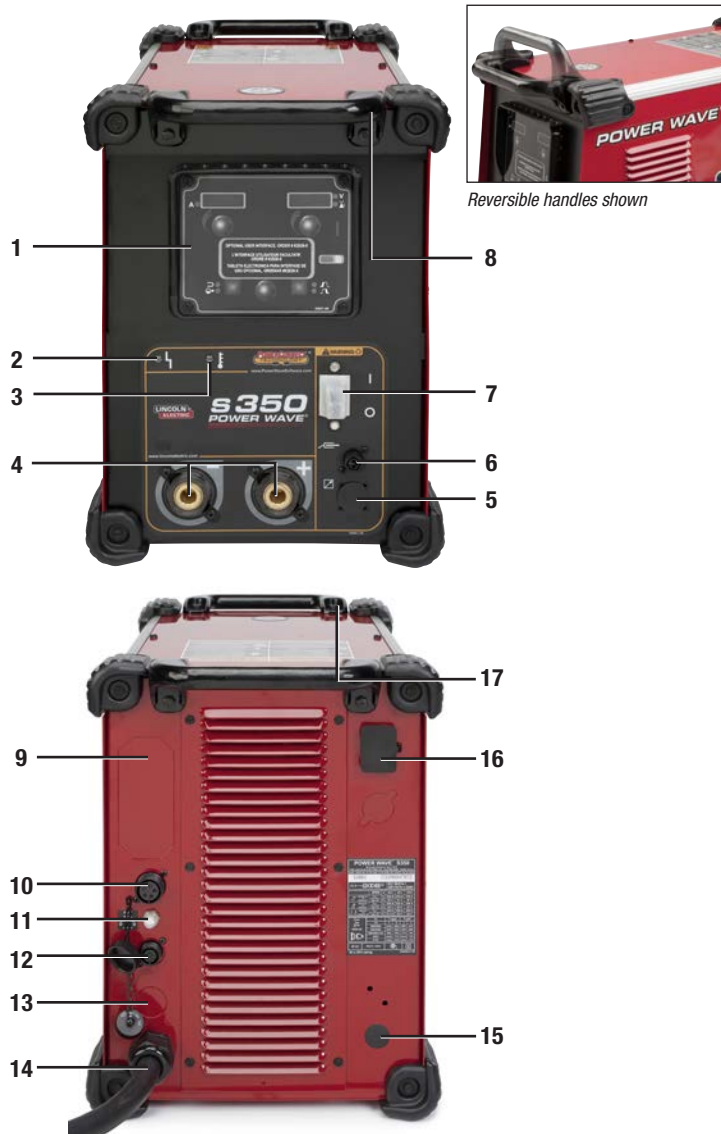

FRONT

1. Optional S-Series User Interface (K3001-2) for Stick, TIG and CV MIG with voltage sensing feeder
2. Status Light
3. Thermal Fault Indicator Light
4. Tweco®-Style Cam-Lock Output Terminals
5. Optional Output Control Receptacle – 12-pin (included with K3001-2 S-Series User Interface)
6. Work Sense Lead Receptacle
7. Main Power Switch
8. Reversible Handles

BACK

9. 115V (10 Amp) AC Duplex Auxiliary Power Receptacle and Circuit Breaker (Optional - Order K2829-1 Kit)
10. ArcLink® Welding System Component Communication Cable Receptacle
11. Circuit Breaker
12. Sync Tandem/STT® Receptacle
13. Optional DeviceNet™ Kit (Requires K2827-2 Kit)
14. Input Power Cable Connection
15. TIG Solenoid Kit Knockout (optional TIG Solenoid included with K3001-2 S-Series User Interface)
16. Ethernet Cable Receptacle
17. Reversible Handles

OPTIONAL K3001-2 S-SERIES USER INTERFACE

To tap into the Power Wave S350 Stick, TIG and CV MIG process capability without a Power Feed® series wire feeder, add the K3001-2 S-Series User Interface Kit. This optional interface provides full control of welding parameters from the front panel of the power source for Stick and TIG processes.

When used with a Power Feed series wire feeder, the feeder is typically used for controlling the system and the K3001-2 S-Series User Interface Kit meters can be used for viewing amps and volts. Kit also includes 12-pin Universal Remote Receptacle and TIG Gas Solenoid.

The S-Series User Interface Kit allows control over:

- **Volts/Amps Control** – Adjust volts in MIG and Flux-Cored welding or adjust amperage in Stick or TIG welding.
- **Welding Mode** – Select the stick, TIG or CV wire process.
- **Advanced Process Options** – Control pre- and post-weld settings to optimize arc starts and stops.
- **Arc Control** – Adjust arc characteristics to match individual preferences.



WHAT'S INCLUDED

Ready-Pak Packages

Ready-Pak packages are assembled and shipped on one pallet. Welding wire and shielding gas must be ordered separately.

Power Wave S350 Ready-Pak (for Steel)

- Power Wave S350 Power Source (K2823-3)
- Power Feed 84 Wire Feeder (Bench Model) (K3328-13)
- .035 in. (0.9 mm) Drive Roll and Split Wire Guide Kit (KP1505-035S)
- .040-.045 in. (1.0-1.2 mm) Drive Roll and Split Wire Guide Kit (KP1505-045S)

- Magnum® PRO Curve™ 400 Gun and Cable Package (K2952-2-10-45)
- Work Lead and Wire Feeder Power Source Cables Package – 350 amps, 60% duty cycle with Tweco style Cam-Lock connectors and Ground Clamp (K1803-2)
- Inverter and Wire Feeder Cart (K3059-4)
- Harris® Flowmeter and Regulator (3100211)

Order K3005-3

TECHNOLOGIES



Tribrid Power Module

Features PowerConnect technology, Planar Transformer™ Technology and 120kHz output to provide exceptional welding performance while still maintaining a high power factor and efficiency.



iARC High Speed Digital Controls

iARC (Intelligent Architecture for Regulation and Control) digital welding controls are faster, include more RAM, and more memory than the previous generation. It also features 100Mbps Full Duplex Ethernet to support Lincoln Electric's CheckPoint.



CheckPoint

CheckPoint, cloud server-based and mobile delivery solutions, is the welding industry's most advanced weld data collection and monitoring tool, allowing fabricators to analyze their welding operations and processes. These tools can provide necessary data for customer ISO, Six Sigma, statistical process control (SPC), quality cost delivery (QCD), overall equipment effectiveness (OEE) and lean manufacturing efforts. CheckPoint is offered at no charge with every Power Wave purchase.



Rugged Reliability

Tested under severe conditions:

- Extreme Temperature Ranges
- Extreme Humidity
- Rain
- Dirt and Dust
- IP23 Rated Performance

RECOMMENDED ACCESSORIES

GENERAL OPTIONS



S-Series User Interface Kit

This kit allows local control of stick, TIG and wire processes from the power source control panel. Includes TIG Solenoid and Remote Control Connector.
Order K3001-2



Dual Cylinder Inverter & Wire Feeder Cart

Rear-wheeled cart with front casters and dual cylinder platform. Convenient handles allow for easy cable storage. Small footprint fits through 30 inch (762 mm) door.
Order K3059-5



LC-40

Tweco-Style Plug (male, 1/0 Thru 2/0)
Order K3416-70



115V Auxiliary Kit

Add a duplex 115V receptacle to the back of the machine. Includes PC board and harness which must be installed.
Order K2829-1



Weld Fume Control Solutions

Lincoln Electric offers a wide variety of weld fume control solutions, ranging from portable systems easily wheeled around the shop to shop-wide central systems servicing many dedicated welding stations.
Request Publication MC08-70



LC-40

Tweco-Style Receptacle (female, 1/0 Thru 2/0)
Order K3417-70



DeviceNet Kit

The kit allows DeviceNet connectivity to control the power source. Includes internal harness and 5-pin DeviceNet™ receptacle for mounting on power source back panel.
Order K2827-2



Tweco Style Cam-Lock Adapter Plug for Work & Electrode Cables

Cable plug for 2/0 (50 mm²) cable.
Order K2946-1



LC-40HD

Tweco-Style Plug (male, 3/0 Thru 4/0)
Order K3416-90



LC-40HD

Tweco-Style Receptacle (female, 3/0 Thru 4/0)
Order K3417-90



Inverter and Wire Feeder Cart

Rear-wheeled cart with front casters and gas bottle platform. Convenient handles allow for easy cable storage. Small footprint fits through 30 in. (762 mm) door. Not intended for use with double head wire feeders.
Order K3059-4



Work Voltage Sense Lead Kit

Required to accurately monitor voltage at the arc.
Order K940-25 for 25 ft. (7.6 m)
Order K1811-50 for 50 ft. (15.2 m)
Order K1811-100 for 100 ft. 30.5 m)



Deluxe Adjustable Gas Regulator & Hose Kit

Accommodates CO₂, Argon, or Argon-blend gas cylinders. Includes a cylinder pressure gauge, dual scale flow gauge and 4.3 ft. (1.3 m) gas hose.
Order K586-1

Shown:
K1811-100

RECOMMENDED ACCESSORIES

General Options Continued



Shown: Cool Arc 55 S

Cool Arc 55 Water Cooler

Designed to integrate with Power Wave S350 and S500 power sources to cool water-cooled welding guns or torches rated up to 500 amps. Recommended for robotic and hand-held MIG, TIG and Plasma cutting operations. 115V/1/60. The 55 S model includes an ArcLink communication flow sensor that detects water flow to prohibit welding when no flow is present. **Order K3086-1** for Cool Arc 55 **Order K3086-2** for Cool Arc 55 S



Foot Amptrol™ with 12-pin Universal Connector

Provides 25 ft. (7.6 m) of remote current control for TIG welding. Requires K3001-2 S-Series User Interface Kit. **Order K870-2**



Parts Kits

Magnum Parts Kits provide all the torch accessories you need to start welding. Parts kits provide collets, collet bodies, a back cap, alumina nozzles and tungstens in a variety of sizes, all packaged in an easy to carry reclosable box. **Order KP508** for PTA-17 **Order KP509** for PTA-26



Magnum PRO AL Air-Cooled & Water-Cooled Push-Pull Guns
The Magnum PRO AL gooseneck style guns are designed to optimize a push-pull welding operation for aluminum. Uses Magnum PRO MIG Gun expendables. Available in 7-pin and 12-pin connections. **Request Publication E12.14**



AutoDrive® 19 Controller
Relays wire feed commands from a Power Wave S-Series power source to any AutoDrive Series robotic wire drive for automated welding operation. Not compatible with Power Wave R-Series power sources. **Order K3004-2**

STICK OPTIONS

Accessory Kit

Complete kit for stick welding. Includes 30 ft. (9.1 m) electrode cable, 25 ft. (7.6 m) work cable, headshield, work clamp and electrode holder. **Order K875** for 150 amps



Hand Amptrol™ with 12-pin Universal Connector

Provides 25 ft. (7.6 m) of remote current control for TIG welding. Requires K3001-2 S-Series User Interface Kit. **Order K963-4**



Power Wave STT Module

This module allows easy connection and fast digital communication with compatible Power Wave S-Series power sources, Power Feed wire feeders, and compatible water coolers. Add STT capability without having to purchase a second power source. **Order K2902-1 US/Int'l** (shown) **Order K2921-1 CE**

Remote Output Control with 12-pin Universal Connector

Permits remote adjustment of output. Requires K3001-1 Stick/TIG User Interface. **Order K857-2** for 25 ft. (7.6 m)



Tweco Style TIG Torch Adapter

Allows a one-cable TIG Torch to connect to the machine's Tweco style output terminal. **Order K960-3**

12-pin to 6-pin Adapter

Allows older 6-pin remote controls (K870, K963-3, K857) to be used with 12-pin Universal Connection. **Order K2909-1**



WIRE FEEDER OPTIONS

Work and Wire Feeder 2/0 Weld Package

Includes Tweco-style Cam-Lock connectors, work clamps, 15 ft. (4.5 m) work cable and 10 ft. (3.0 m) electrode cable. Rated 350 amps, 60% duty cycle. **Order K1803-2**



Power Wave Advanced Module
Provides multi-process reverse polarity (DC+), straight polarity (DC-), AC, high frequency TIG and STT functionality. Compatible with Power Wave S350 and S500. **Order K2912-1**

TIG OPTIONS

PTA-26FV 200 Amp Air-Cooled TIG Torch

Order K1783-11 for 12.5 ft. (3.8 m) length, 1-cable. With Tweco-style adapter.



PRODUCT SPECIFICATIONS

Product Name	Product Number	Input Voltage	Input Current @ Rated Output	Rated Output Current/Voltage/Duty Cycle	Output Range ⁽³⁾	H x W x D inches (mm)	Net Weight lbs. (kg)
Power Wave S350	K2823-3	208/230/380-415/460/575/1/3/50/60	3 Ph / 40% Duty Cycle: 39/35/19/17/14 3 Ph / 100% Duty Cycle: 31/28/15/14/11 1 Ph / 40% Duty Cycle: 60/67 ⁽¹⁾ /NA/NA/NA 1 Ph / 100% Duty Cycle: 60/53/NA/NA/NA	GMAW: 350A/31.5V/40% ⁽²⁾ GMAW: 300A/29V/100% SMAW: 325A/33V/40% ⁽²⁾ SMAW: 250A/30V/100% GTAW-DC: 350A/24V/40% GTAW-DC: 300A/22V/100%	5-350A	20.40 x 14 x 24.80 (518 x 356 x 630)	85 (38.6)
Power Wave S350 Ready-Pak (Steel)	K3005-3					52 x 39 x 26 (1321 x 991 x 660)	450 (204.1)

⁽¹⁾ Based on the U.S. National Electrical Code

⁽²⁾ On 230 Volt / 1 Phase inputs, the peak rating is at a duty cycle of 30%, except for GTAW processes

⁽³⁾ On 208 Volt inputs, the maximum output is limited to 300 amps

For best welding results with Lincoln Electric equipment, always use Lincoln Electric consumables. Visit www.lincolnelectric.com for more details.

CUSTOMER ASSISTANCE POLICY

The business of The Lincoln Electric Company is manufacturing and selling high quality welding equipment, consumables, and cutting equipment. Our challenge is to meet the needs of our customers and to exceed their expectations. On occasion, purchasers may ask Lincoln Electric for information or advice about their use of our products. Our employees respond to inquiries to the best of their ability based on information provided to them by the customers and the knowledge they may have concerning the application. Our employees, however, are not in a position to verify the information provided or to evaluate the engineering requirements for the particular weldment. Accordingly, Lincoln Electric does not warrant or guarantee or assume any liability with respect to such information or advice. Moreover, the provision of such information or advice does not create, expand, or alter any warranty on our products. Any express or implied warranty that might arise from the information or advice, including any implied warranty of merchantability or any warranty of fitness for any customers' particular purpose is specifically disclaimed.

Lincoln Electric is a responsive manufacturer, but the selection and use of specific products sold by Lincoln Electric is solely within the control of, and remains the sole responsibility of the customer. Many variables beyond the control of Lincoln Electric affect the results obtained in applying these types of fabrication methods and service requirements.

Subject to Change – This information is accurate to the best of our knowledge at the time of printing. Please refer to www.lincolnelectric.com for any updated information.

LINCOLN
ELECTRIC
THE WELDING EXPERTS®